

IONIAN QUARRRYCAST FREESTANDING BATH 1700 X 795 X 614

victoria ⊕ albert[®]

52090.10

\$6179.00

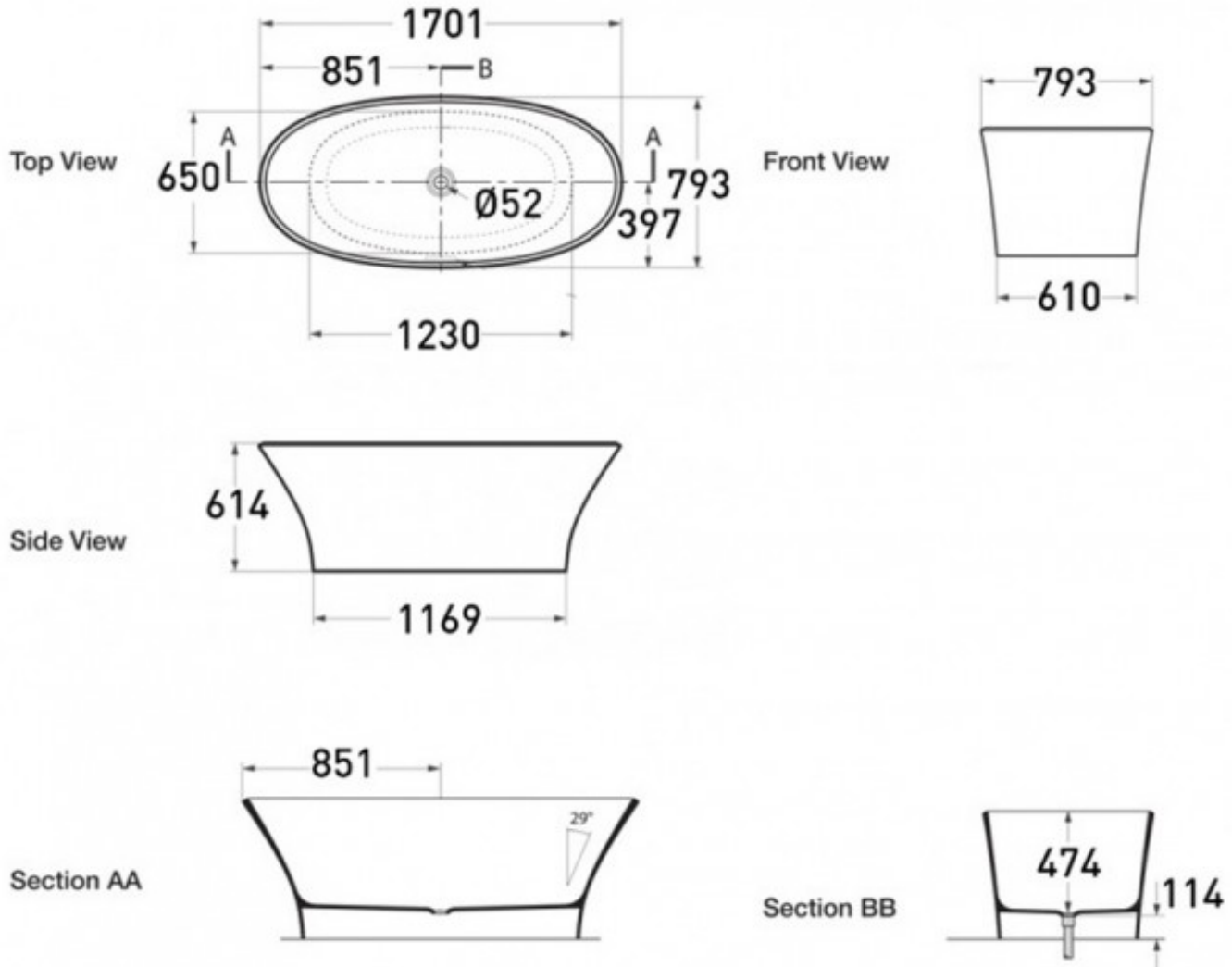

25

Guarantee

25 Year Guarantee



Dimensions

1700 (L) x 795 (W) x 614 (H)mm



Residential Use

Suitable for Residential/Light Commercial Use (Kitchens, Bathrooms and Laundries in Motels, Hotels and Retirement Villages)



Commercial Use

Suitable for commercial use.



Capacity

310 Litres



Outdoor Use

Can be installed inside or outdoors.



Quarrycast

QUARRRYCAST[®] material is made from a finely ground volcanic limestone and resin mix. 100% one piece, hand finished and packed with naturally desirable properties.





Exterior Painting

Exterior can be painted or personalised.



Weight

82KG



Cleaning
Recommendations

We recommend any non-abrasive bathroom or kitchen cleaner however care should be taken with some products as they can damage the metal drain parts inside the bath. Abrasive cleaning products will cause the disappearance of the gloss finish over time.



British owned and
operated



Made in South Africa

The Ionian modern free standing bath draws inspiration from the los and features a variable width rim and a dramatic oval design for the ultimate in comfort.