

MONACO QUARRYCAST FREESTANDING BATH 1740 X 800 X 612

victoria ⊕ albert<sup>®</sup>

52025.10  
\$2719.00

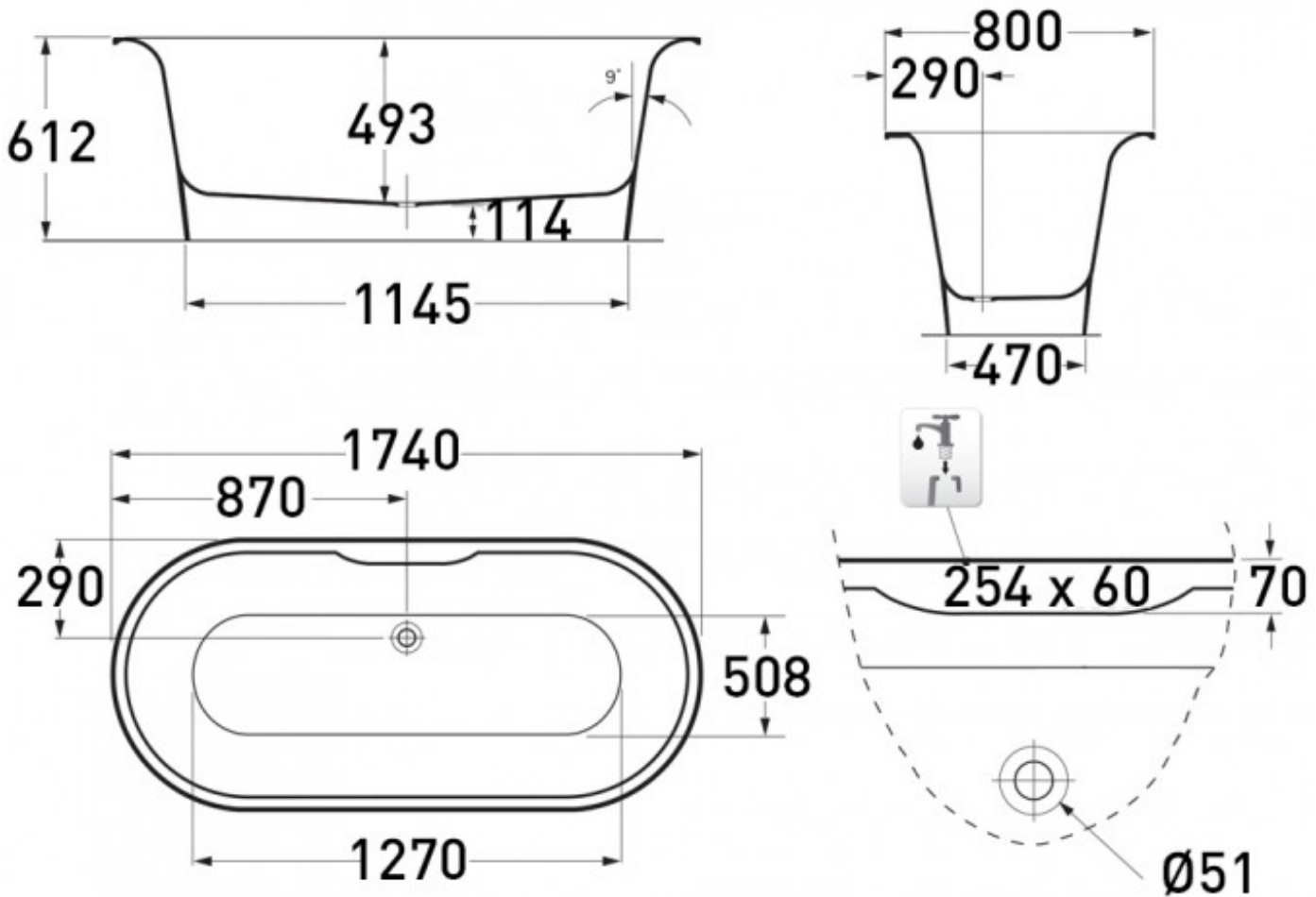

25

Guarantee

25 Year Guarantee



Dimensions

1740 (L) x 800 (W) x 612 (H)mm



Residential Use

Suitable for Residential/Light Commercial Use (Kitchens, Bathrooms and Laundries in Motels, Hotels and Retirement Villages)



Commercial Use

Suitable for commercial use.



Capacity

220 Litres



Outdoor Use

Can be installed inside or outdoors.



Quarrycast

QUARRYCAST<sup>®</sup> material is made from a finely ground volcanic limestone and resin mix. 100% one piece, hand finished and packed with naturally desirable properties.





Exterior Painting

Exterior can be painted or personalised.



Weight

64KG



Cleaning  
Recommendations

We recommend any non-abrasive bathroom or kitchen cleaner however care should be taken with some products as they can damage the metal drain parts inside the bath. Abrasive cleaning products will cause the disappearance of the gloss finish over time.



British owned and  
operated



Made in South Africa

A beautifully crafted rimless freestanding bath, designed with confident curves and ergonomic design, Monaco delivers a strong architectural presence in compact bathroom spaces.